

Flowhead Cleaning Instructions

Applicable to devices using Vitalograph Number 4 Fleisch Flowhead part number 61030 Including antecedent versions of the Pneumotrac, ALPHA, ALPHA Touch, COMPACT.

Hygiene Policy

Vitalograph spirometers are not designed to be, nor supplied as, sterile.

Vitalograph intends that a new Bacterial Viral Filter (BVF) be used for every subject to prevent cross contamination. Using a BVF provides a significant level of protection of the subject, the device and the user against cross contamination during spirometry manoeuvres.

The interior of a Vitalograph flowhead does not require decontamination where a new BVF is used for each subject. When used according to Vitalograph recommendations, Vitalograph spirometers are considered non-critical or low risk with regard to infection control. The exterior of the flowhead may be cleaned in line with local requirements for hand held objects².

If a higher level of decontamination is required, then cleaning may be followed by disinfection as outlined below.

Cleaning the Flowhead Exterior

Recommended cleaning method where a new BVF is used for every subject:

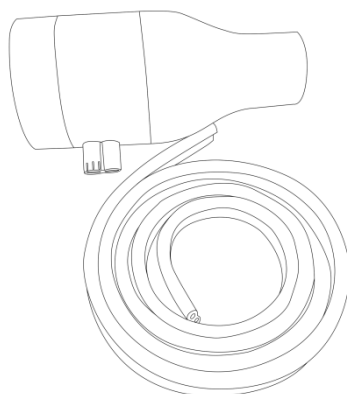

Figure 1: Flowhead Complete + Flowhead Connection Tubing

1. Disconnect both ends of flowhead connection tubing from pressure tapping.
2. Use a 70% isopropyl alcohol impregnated cloth to clean the case exterior of the flowhead and the flowhead connection tubing.
3. Reassemble by reconnecting the flowhead connection tubing to pressure tapings on flowhead carrier and flowhead.
4. Vitalograph recommends that calibration verification be carried out following reassembly to verify correct operation and accuracy. Instructions for calibration verification are contained in the device instructions for use.

² Vitalograph (2019), "Hygiene Policy". Internal Vitalograph policy. Document number: SOP_0523.

Decontamination by Cleaning and Disinfection

This is the recommended cleaning method where the user suspects that the flowhead interior may have become contaminated or if a user's local requirements for handheld items includes disinfection.

Cleaning of Flowhead Interior

1. Disconnect the flowhead connection tubing from the flowhead and flowhead carrier.

Disassemble the Fleisch flowhead:

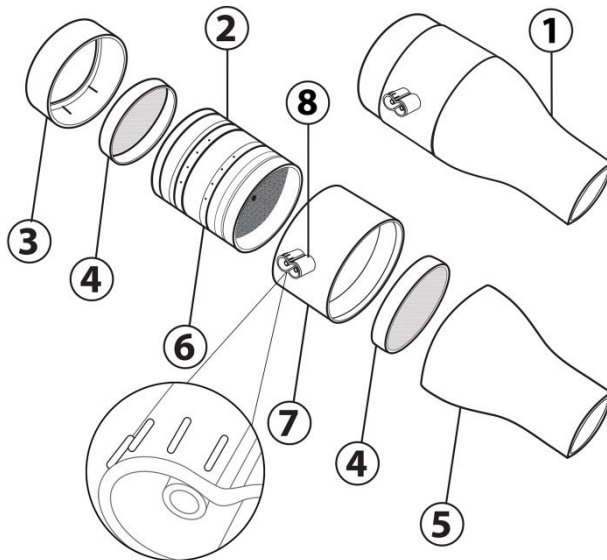

1	Flowhead Complete
2	'O' Rings
3	Flowhead End Cap
4	Flow Conditioning Meshes
5	Flowhead Cone
6	Fleisch Element (containing coil/ capillaries)
7	Flowhead Body
8	Port Pressure Tappings

Figure 2: Flowhead Assembly

2. Remove cone and end cap from flowhead.
3. Remove flow conditioning meshes from inside the cone and end cap. Examine for damage or contamination. If meshes are damaged or blocked, discard and replace with new parts.
4. Remove flowhead body from Fleisch element. To do this, place the Fleisch element on a hard, flat surface with the largest diameter at the top (this is the end with an 'O' ring showing). Push down on the flowhead body with thumbs and forefingers until it reaches the flat surface. A final pulling and twisting action will separate the parts.
5. **Cleaning.** Swill Fleisch element vigorously in warm soapy water. Do not attempt to "rub" or "scrub" at the capillaries formed by the coil.
6. Wash the flowhead end cap, flowhead body, flow conditioning meshes and flowhead cone in warm soapy water. Rub surfaces to remove any visible soiling.
7. Ensure all parts are visibly clean. If not visibly clean repeat the cleaning process.
8. Rinse with potable tap water.

If disinfection is required, proceed to disinfection steps after rinsing, otherwise proceed straight to drying.

Reassembly of Fleisch Flowhead

1. Examine Fleisch element and flowhead body to ensure that no liquid or particles remain in the holes or grooves.
2. Check 'O' rings for damage and ensure correct positioning within the grooves.
3. Apply a very small amount of silicone grease to 'O' Rings and inside the surfaces of the flowhead body. Wipe off any visible amounts of grease. Ensure that the tiny annular holes on the outside of the Fleisch element are not blocked.
4. Refer to *Figure 2: Flowhead Assembly* to view placement of parts for reassembly.
5. Replace flowhead body onto Fleisch element. Ensure the pressure tapping on the flowhead body is nearest to the largest diameter (rear) of the Fleisch element.

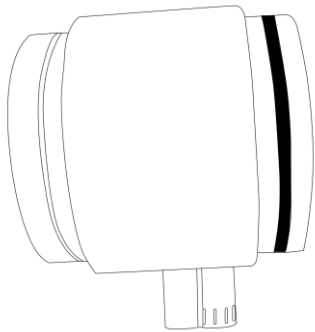
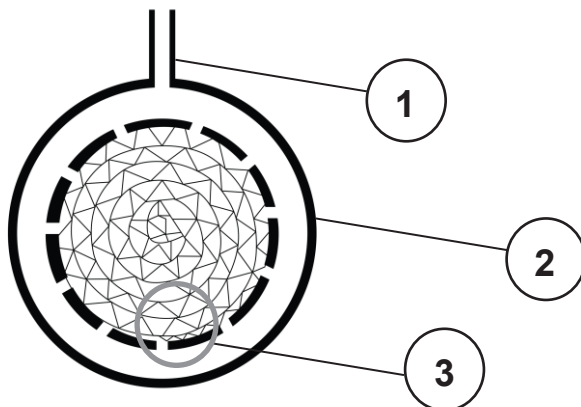

Figure 3: Replacing the flowhead body onto the Fleisch element

6. Ensure that flowhead body is pushed fully home, and rotate it so that the port pressure tappings are approximately 180° opposite the end of the Fleisch element coil.



1	Port Pressure Tappings
2	Flowhead Body
3	End of the Fleisch Element Coil

Figure 4: Orientating the Fleisch element coil at 180° to the port pressure tappings

7. Fit flow conditioning meshes to both flowhead cone and flowhead end cap.
8. Push flowhead end cap onto the larger diameter of the Fleisch element and push flowhead cone onto the smaller diameter.
9. Reconnect flowhead tubing.

Vitalograph recommends that calibration verification be carried out following reassembly to verify correct operation and accuracy. Instructions for calibration verification are contained in the device instructions for use.

Consumables Ordering Information

Cat. No	Description
28350	BVF - Bacterial/Viral Filters (50)
28501	Eco BVF – Bacterial/Viral Filters (100)
28572	Eco BVF and Disposable Nose Clip (80)
36020	3-L Precision Syringe
42084	Flow Conditioning Mesh (10)
61030	Flowhead Complete
42029SPR	Flowhead Connection Tube
77939	Flowhead Cone
77938	Flowhead End Cap
2120013	O-Ring (15)
32254SPR	Silicone Grease
60062	Service kit for Pneumotracs and Alpha

References

1. Steris Device Testing (2016) *“External Summary Report Device Testing”* Dated 20 October 2016. Internal report for Vitalograph Ireland Ltd. Report Number: 10250035. A Mentor, OH. STERIS Corporation.*
2. Vitalograph (Ireland) Ltd (2014) *“Testing the recommended cleaning method – Report Pneumotracs Flowhead”* Dated 13 May 2014. Internal Vitalograph report. Report number: P229_0038.*
3. Vitalograph (2019), *“Hygiene Policy”*. Internal Vitalograph policy. Document number: SOP_0523.*

Bibliography

1. Bentz, J. R. (2019). *“Bacterial Filtration Efficiency (BFE) at an Increased Challenge Level Final”* Study Number 1138681-SGI; *“Viral Filtration Efficiency (VFE) at an Increased Challenge Level Final”* Study Number 1138680-S01. Internal reports for Vitalograph Ireland Ltd dated 17 January 2019. Nelson Laboratories, Salt Lake City.*
2. Bracci, M. et al (2011). "Risk of bacterial cross infection associated with inspiration through flowbased spirometers." *American Journal of Infection Control* **39**(1): 50-55. DOI: <https://doi.org/10.1016/j.ajic.2010.04.215>.
3. Dunne, C (2019). *“Calibrated Flow Bioburden testing of Vitalograph Alpha Flow Heads”* Dated 16 July 2019. Internal report for Vitalograph Ireland Ltd.*
4. FDA (2015) *“Reprocessing Medical Devices in Health Care Settings: Validation Methods and Labeling Guidance for Industry and Food and Drug Administration Staff”* U.S. Food & Drug Administration.
5. FDA (2018). *“What are Reusable Medical Devices?”* U.S. Food & Drug Administration. Accessed 4 July 2019, from <https://www.fda.gov/medical-devices/reprocessing-reusable-medical-devices/what-are-reusable-medical-devices>

6. Kendrick, A. H. et al (2003). "Infection control of lung function equipment: a practical approach." *Respiratory Medicine* **97**(11): 1163-1179. DOI: [https://doi.org/10.1016/S0954-6111\(03\)00223-3](https://doi.org/10.1016/S0954-6111(03)00223-3)
7. Loveday, H. P. et al (2014). "epic3: National Evidence-Based Guidelines for Preventing Healthcare-Associated Infections in NHS Hospitals in England." *Journal of Hospital Infection* **86**: S1-S70. DOI: [https://doi.org/10.1016/S0195-6701\(13\)60012-2](https://doi.org/10.1016/S0195-6701(13)60012-2).
8. NHS (2017). Community Infection Prevention and Control Guidance for General Practice. Infection Prevention Control. UK. Accessed 28 May 2019, from <https://www.infectionpreventioncontrol.co.uk/>
9. Rutala, W. A., D. J. Weber and HICPAC (2008). "Guideline for Disinfection and Sterilization in Healthcare Facilities." CDC Infection Control Accessed 28 May 2019, from <https://www.cdc.gov/infectioncontrol/guidelines>

* Data from internal reports and policies may be made available by request to Vitalograph.